



BOSCH



Bosch
KDN64VL20N
Refrigerator/ solo

Predecessor:

Successor:

EAN code:
4242002707792

sales programme:

Top freezer
KDN64VL20N
No Frost

Performance and Consumption

- Energy efficiency class: A+
- Annual energy consumption 419 kWh (per year).
- Total net capacity: 492 litres
- Net fridge capacity: 350 litres
- Net freezer capacity: 142 litres
- Noise level dB(A) re 1 pW: 44

Design features

- Stainless steel look doors and grey side panels
- aluminium Vertical door handle
- Bright interior LED fridge light
- Electronic LED display
- Removable magnetic door seals - easy to clean
- 1 compressor

Food freshness system

- MultiAirflow system - improves circulation of air around the fridge
- ChillerBox - recommended storage area for meat and fish

Key features - Fridge section

- SuperCool function with automatic deactivation
- Interior design with metal applications
- 3 removeable safety glass shelves of which 2 are easy pull out
- 4 removable door storage compartments.
- Bright interior LED fridge light

Key features - Freezer section

- Twist ice dispenser in freezer
- **** freezer 163 l (-18°C and below)
- No Frost, never have to defrost ever again
- 4 star freezer rating
- VarioFreezing - adaptable storage for more flexibility
- Freezing capacity in 24 hours: 6 kg
- Maximum freezer storage time in power failure: 18 hours

Functions

- SuperCool function with automatic deactivation
- Optical and accoustical door open warning signal
- Removable magnetic door seals - easy to clean

Dimension and installation

- Climate class T
- 220 - 240 V
- Height adjustable front feet
- Dimensions: 177 cm H x 76.8 cm W x 73.4 cm D

Included accessories

1 x egg tray

Optional accessories

Alternative colors available

Technical Data

Characteristics

Built-in / Free-standing : Free-standing
 Door panel options : Not possible
 Height (mm) : 1770
 Width of the product (mm) : 768
 Depth of the product : 734
 Net weight (kg) : 85.000
 Connection Rating (W) : 205
 Current (A) : 10
 Door hinge : Right
 Voltage (V) : 220-240
 Frequency (Hz) : 50
 Approval certificates : CE
 Length electrical supply cord (m) : 200.00
 Storage Period in Event of Power Failure (h) : 18
 Number of compressors : 1
 Number of independent cooling systems : 1
 Interior ventilator : Yes
 Reversible Door Hinge : No
 Number of Adjustable Shelves in fridge compartment (Stck) : 2
 Shelves for Bottles : No

Consumption and connection features

Brand : Bosch
 Product name / Commercial code : KDN64VL20N
 Energy efficiency class - NEW (2010/30/EC) : A+
 Energy consumption annual (kWh/ annum) - NEW (2010/30/EC) : 419
 Refrigerator Net capacity (l) - NEW (2010/30/EC) : 350
 Freezer Net capacity (l) - NEW (2010/30/EC) : 142
 Frost free system : Full
 Temperature rise time (h) : 18
 Freezing capacity (kg/24h) - NEW (2010/30/EC) : 6
 Climate class : T
 Noise level (dB(A) re 1 pW) : 44
 Installation typology : N/A



BOSCH

Top freezer
KDN64VL20N
No Frost

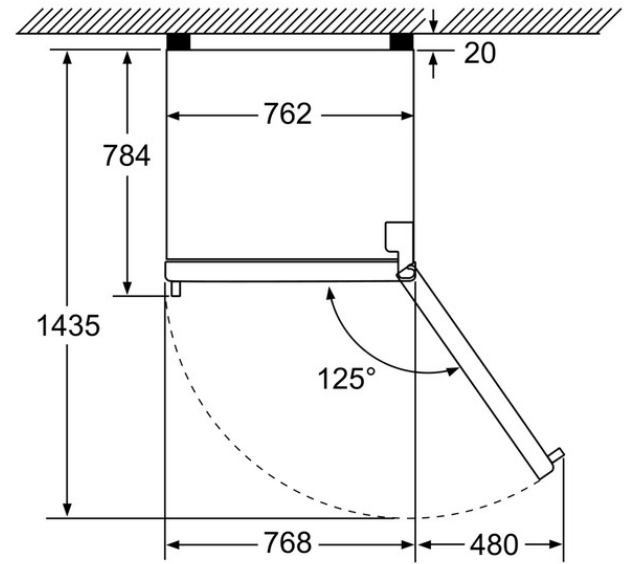

measurements in mm